



THERMOCHEM[®]

Empowering Energy Industries since 1985

**Specifications for Well Testing Facilities
and Instrumentation**

for High-Accuracy Well Testing Operations

Thermochem 40 x 40 LECM

Contents

1	WELL TEST FACILITY DESIGNS	2
	1.1 Operating Specifications	6
2	CODES AND STANDARDS.....	7
3	INSTRUMENTATION	8
	3.1 Required Instrument Specifications and Accuracy	8
	REFERENCES	9

1 Well Test Facility Designs

Geothermal Well Testing has traditionally been performed using atmospheric cyclone separators with a James Tube at the inlet to measure total mass flow and a weir box at the outlet to measure brine flow (**Figure 1**). The James Tube calculation requires enthalpy as an input which can be determined by iteration of the total mass flow and the separated brine flow. This technique has been used without modification or improvement for over 40 years (James, 1966). Accuracy estimates for total mass flow by this method range from +/- 5 to +/- 25% (Jung, 2001).

Occasionally production separators are used at production operating pressures with conventional single-phase flowmeters to measure the separated steam and brine flowrates (**Figure 2**). This system can produce higher accuracy data than the James Tube / weir box method, but it is much costlier, has limited turn-down capability and generally not suitable for initial start-up and warming operations of geothermal wells which must be done at low pressures. Low-pressure steam would overwhelm the capacity of a high-pressure separator. Accuracy of total mass flow measurement by this method should be +/- 5 % or better, with enthalpy on the order of +/- 10 kJ/kg.

Thermochem developed an alternative Geothermal Well Testing Facility in 2010 based on a compact atmospheric separator system built around shipping containers. A James Tube is used at the inlet and brine metering manifold at the outlet equipped with high-accuracy Magnetic Flowmeters for brine measurement (**Figures 3 - 5**). This "Low-Emissions Compact Muffler" (LECM), utilizes baffles in the lower container separator unit and mist pads in the upper container dryer unit to minimize carry-over. A key aspect of the design is the large surface area of the dryer outlet to maintain steam exit velocity below a maximum, which if exceeded will result in brine carry-over (Easley, 2018). The James Tube method can produce remarkable accuracy for well testing when reliable brine flow measurement is available, with total mass flowrate accuracies within about +/- 5% or better, comparable to conventional single-phase flowmeters, and total fluid enthalpy accuracies within about +/- 12 kJ/kg, comparable to flowing PT survey enthalpy and TFT[®] measurements (Hirtz, 2001).

The LECM has inherent advantages over the conventional atmospheric cyclone separator design in lower brine droplet emissions at the same flowrate and steam exit velocity, and ease of transport. Commercial stainless-steel mist elimination pads remove fine droplets and aerosols, resulting in very low brine carry-over up to full load. Excessive brine carry-over leads to an under-estimation in brine flow and over-estimation of total enthalpy. This is critically important for high-enthalpy wells. Brine carry-over is also an important environmental and local community impact concern.

The 40 x 40 ft. LECM is fabricated with the same outside dimensions as ISO shipping containers (8 ft. wide), which allows the pre-fabricated mufflers to be transported by standard trucking and ocean freight shipping lines worldwide, even to very remote areas. An equivalent capacity cyclone muffler would need to be at least 25 ft. in diameter, which precludes transport on most public roads, requires fabrication on-site and would still not provide the same efficiency or accuracy as an LECM.

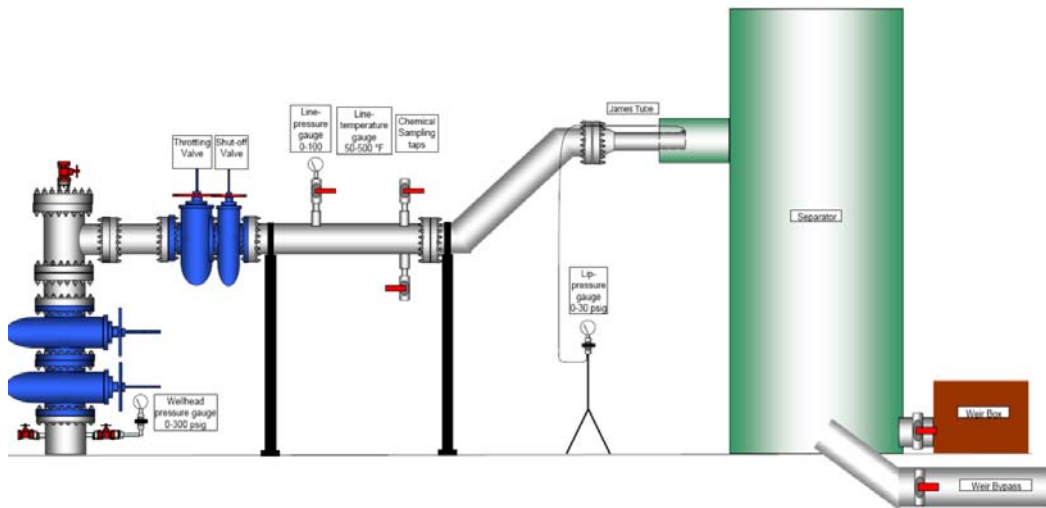
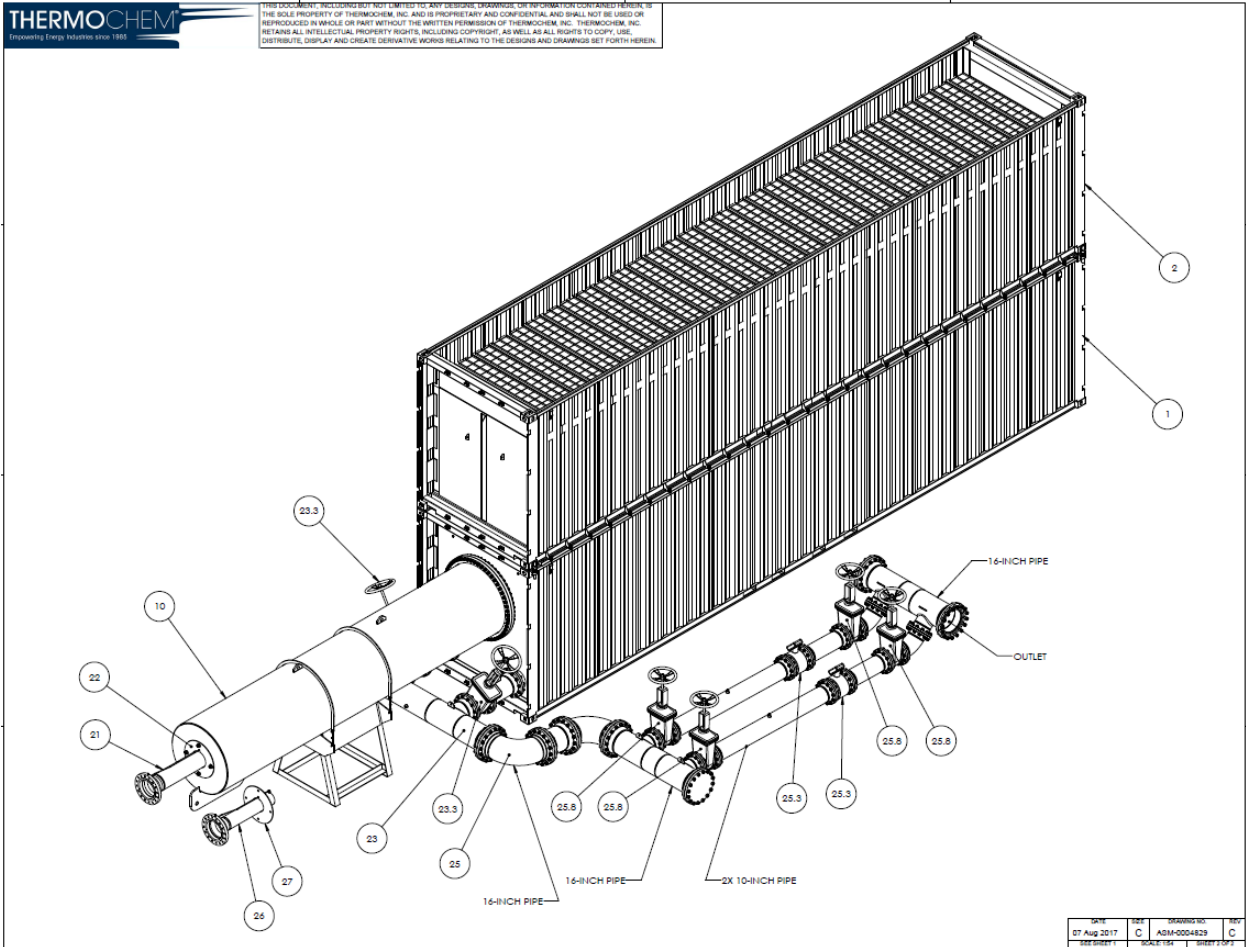

Figure 1. James-tube, Atmospheric Separator and Weir Box



Figure 2. Production Test Separator



ITEM NO.	PART NUMBER	DESCRIPTION	QTY.
1	ASM-0002287	ASSEMBLY, 40FT LECM SEPARATOR	1
2	ASM-0002289	ASSEMBLY, 40FT LECM DRYER	1
10	ASM-0002325	48-INCH EXPANSION PIPE, ASSEMBLY	1
21	ASM-0002521	10-INCH JAMES TUBE ASSEMBLY	1
22	PRT-0002652	JAMES TUBE ADAPTER, 10-INCH, EXPANSION PIPE	1
23	ASM-0004219	BRINE OUTLET HEADER, 16X12	1
23.3	MTL-0001593	GATE VALVE, 12-INCH NPS	2
25	ASM-0004232	BRINE DRAIN MANIFOLD 16X10	1
25.3	MTL-0001443	FLOWMETER, ELECTROMAGNETIC, 10-INCH FLANGES	2
25.8	MTL-0004409	GATE VALVE, 10-INCH NPS	4
26	ASM-0002519	8-INCH JAMES TUBE ASSEMBLY	1
27	PRT-0002651	JAMES TUBE ADAPTER, 8-INCH, EXPANSION PIPE	1

Figure 3. Thermochem 40 ft. x 40 ft. LECM (40 x 40)



Figure 4. LECM in Bolivia



Figure 5. LECM in Sumatra

1.1 Operating Specifications

The typical maximum flowrates and normal operating pressures for a 40 x 40 LECM are summarized in **Table 1**.

Table 1. 40 x 40 LECM Typical Max Flow Rating and Operating Pressures		
Process Location	Max Pressure (psig)	Max Flow (ton/h)
Diffuser Inlet, Total Fluid	5.0	850
Muffler, Steam Vent (upper stack)	0.025	250
Muffler, Brine Metering Manifold	2.0	600

In order to achieve the required accuracy of an LECM, a brine metering manifold with multiple legs and Magnetic Flowmeters is required. A weir box or strap-on ultrasonic flowmeter cannot provide an adequate degree of accuracy. The critical design specifications for a 40 x 40 LECM are listed in **Table 2** below.

Table 2. Critical Design Specifications for LECM	
Process Location	Parameter
Outlet, Total Steam Mass Flow	250 t/h, 40 x 40 Maximum Capacity at atmospheric flash
Outlet, Total Brine Mass Flow	600 t/h, 40 x 40 Maximum Capacity at atmospheric flash (3-leg manifold)
Inlet, Total Fluid Mass Flow	850 t/h, 40 x 40 Maximum Capacity, limited by sum of maximum steam and brine flows above
Muffler Body, Liquid Containment	Baffle Plates to provide primary separation
Muffler Stack, Droplet Control	High-Efficiency Mist Eliminator Mesh Pads
Muffler Stack, Steam Vent Velocity	< 4 m/s
Muffler Stack, Brine Carry-over	< 0.25% of Inlet Brine Flow
Muffler Drain Water Level	Passive Level Control to ensure flooded meters
Muffler Drain Meter Run Velocity	0.3 – 2 m/s

2 Codes and Standards

Table 3. lists the codes and standards used in design of an LECM, two-phase piping and brine metering manifold piping, including flanges, structural steel, bolts and gaskets.

Table 3. Codes & Standards		
Code & Standard	Title	Assembly
ASME B31.1	Power Piping	Two-Phase piping, Brine Manifold piping
ASME BPVC, SECTION IX	Welding Qualifications	Two-Phase piping, Brine Manifold piping
AWS D1.1	Structural Welding	LECM, Supports
ASME B16.5	Pipe flanges and fittings	Two-Phase piping, Brine Manifold piping
ASTM A106	Pipe, Seamless carbon steel	Two-Phase piping
ASTM A53	Pipe, welded and seamless	Brine Manifold piping
ASTM A36	Structural carbon steel	LECM, Supports
ASME B16.9	Wrought butt welding fittings	Two-Phase piping, Brine Manifold piping
ASTM A193	Alloy steel bolting	Two-Phase piping, Brine Manifold piping
ASTM A194	Carbon and alloy steel nuts	Two-Phase piping, Brine Manifold piping
ASME B16.20	Metallic gaskets for pipe flanges	Two-Phase piping, Brine Manifold piping
EBTKE (Indonesia)	Requires review of WPS, and visual inspection of complete system on-site	

3 Instrumentation

For an LECM well test facility designed to collect accurate flow testing data, the two-phase piping and brine metering manifold must be equipped with the instrumentation as listed in **Table 4**. This instrumentation as supplied by Thermochem typically includes a wellhead pressure transmitter, line pressure transmitter, line temperature transmitter, James tube lip pressure transmitter, and brine manifold magnetic flowmeters. A wellhead temperature transmitter is also recommended to allow estimation of NCG in fluid.

3.1 Required Instrument Specifications and Accuracy

For most well test operations, the standard recommended instrument ranges and the required accuracies are listed in **Table 4**. A PLC-based data logging system is provided by Thermochem for accurate and reliable data logging with redundant storage to independent USB memory. This system includes a graphic HMI display for all parameters so well test personnel can quickly assess flow test facility status. The PLC-based system provides real-time processing of mass flowrates and enthalpy. This equipment is interfaced to a reliable power supply, such as a PV solar power system with battery back-up. Internet connection for data upload and remote access is a very useful option for remote monitoring.

Process Location	Measurement Range	Calibrated Range	Accuracy
Wellhead Pressure	0 – 3000 psia	0 – 1000 psia	+/- 0.65 psia
Wellhead Temperature	0 – 400 °C	0 – 250 °C	+/- 0.2 °C
Two-Phase Line Pressure	0 – 800 psia	0 – 500 psia	+/- 0.32 psia
Two-Phase Line Temperature	0 – 400 °C	0 – 250 °C	+/- 0.2 °C
James Tube Lip Pressure	-300 – 300 psi	0 – 120 psia	+/- 0.08 psia
Brine Manifold Leg (10 in.)	50 – 500 m ³ /h	50 – 500 m ³ /h	+/- 0.8 – 0.3 %

References

Easley, E., Nurlianto, “Geothermal Well Testing Using a New Atmospheric Separator and Metering System”, Proceedings, The 6th Indonesia International Geothermal Convention & Exhibition (IIGCE), 2018.

Hirtz, P., Kunzman, R., Broaddus, M., and Barbitta, J. “Developments in Tracer Flow Testing for Geothermal Production Engineering,” *Geothermics*, vol. 30, pp. 727–745, 2001.

James, R., “Measurement of Steam-water mixtures Discharging at the Speed of Sound to Atmosphere”. *N.Z. Engineering*, pp. 437 – 441, 1966.

Jung, D., “Geothermal Flow Metering Application and Error”, Geothermal Resource Council Flow Measurement Workshop, 2001.

ABOUT THERMOCHEM

Thermochem is a vertically integrated consultancy, service, and OEM instrument firm empowering energy industries since 1985. Our mission is to protect the assets and resources of our clients, ensuring the most efficient use of equipment and resources, through preventing corrosion and scale damage to valuable equipment and providing early detection and solutions to resource problems. We service clients in more than 30 countries, providing chemical engineering solutions and equipment for geothermal energy, oil and gas, combined cycle, cogeneration and fossil fuel power plant projects from our offices and laboratories based in the USA and Indonesia.

We provide solutions to our clients from the ground up: exploration through operations. Our extensive range of products and services includes greenfield exploration, well testing, geochemical modeling, chemical process engineering, analytical chemistry, reservoir engineering, permit support, due diligence and specialized instrumentation such as two-phase wellbore samplers, pH-modification equipment and on-line steam quality and purity meters.